

Prima Vista

SLIDING PATIO DOOR COLLECTION



**Securway**
Manufacturing Corp.

A Statement of Style

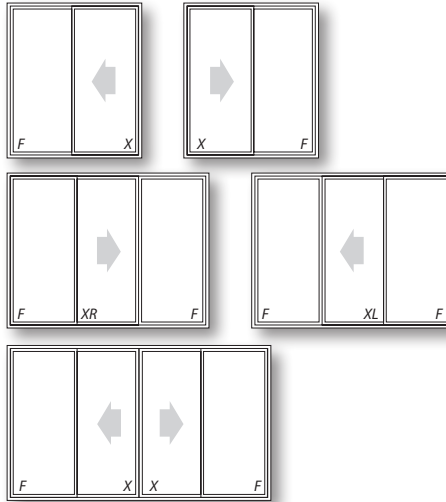

Integral Lift and Tilt Mini Blinds & Shades

Standard tempered 7/8" insulated glass with high performance Low E, argon gas, and Endur warm edge spacer.

Elegant Hardware

Prima Vista sliding patio doors are built with a strong, dependable multi-point locking system for optimum resistance and protection against forced entry. Prima Vista's hardware is encased in galvanized steel reinforcement for additional security and is available with or without key locks. Prima Vista doors also offer an optional foot lock for added protection.

Hardware is offered in a variety of finishes including white, black, or beige coated, or decorator hardware in brass, brushed chrome, or black nickel. Two-toned hardware is also available as a special order option.

Designer Colors & Finishes

Prima Vista sliding patio doors are offered in white, beige, light oak, medium oak and cherry interior finishes, with optional interior or exterior Designer Colors available to match your home.

Configurations & Decorative Options

- 2-panel, 3-panel, 4-panel configurations
- Standard tempered 7/8" insulated glass with high performance Low E, argon gas, and Endur warm edge spacer
- Contoured grids in all white, all beige, or woodgrain with any standard exterior color*
- Flat grids in all white, all beige, or white with any standard exterior color*
- Slim line grids in white or gold*

*Grids are offered in a prairie or colonial pattern. Subject to availability.

More than just energy savings ... a history of environmental commitment.

Each Prima Vista patio door contains "Nucleus technology," an eco-efficient PVC core designed to maximize material efficiencies and performance. We have worked together with our supplier partners for decades to reduce waste, optimize energy and water consumption, and reduce the impact of transportation. The NUCLEUS technology in our Prima Vista patio door is a part of those efforts and represents nearly a decade of hard work and investment.



White, Black, or
Beige Coated



Brass



Brushed Chrome



Black Nickel

Designer Interior Colors



Designer Exterior Colors



Prima Vista's Specialty Features

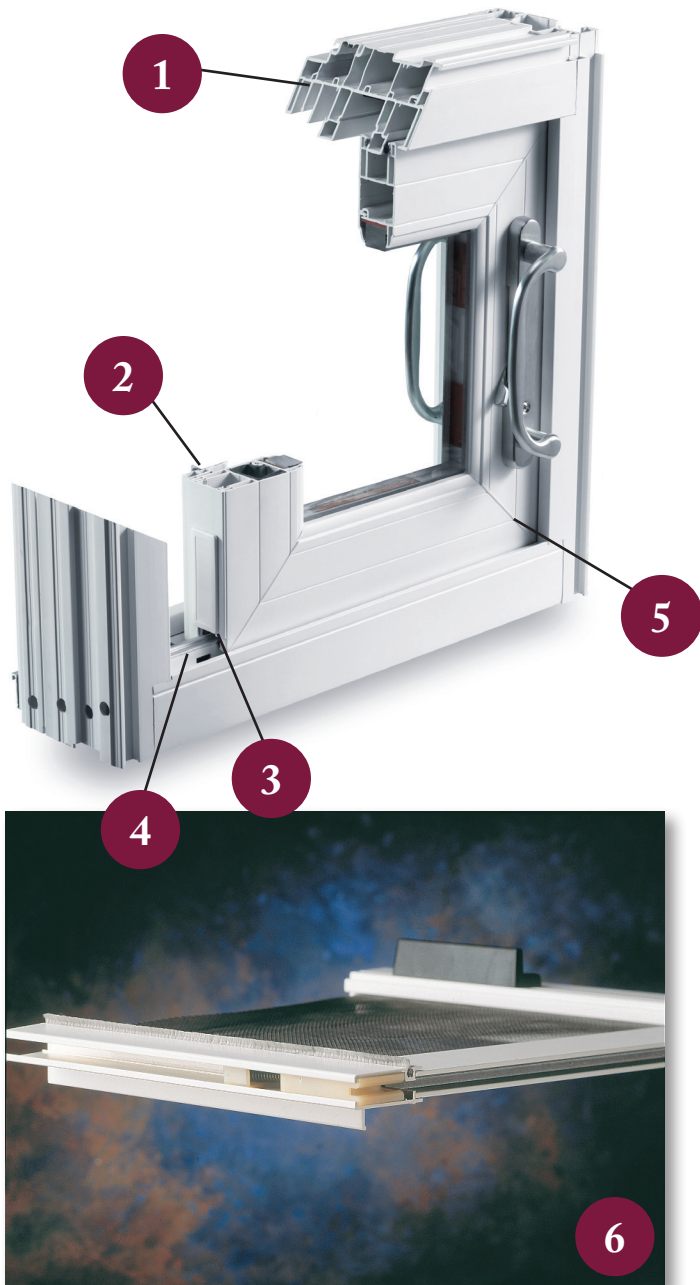

1. Strong, heavy-duty multi-chamber uPVC vinyl extrusions offer superior thermal efficiency and increased sound dampening.
2. Triple weather stripping on posts and double weather stripping at the secure interlock for enhanced insulation, virtually eliminates air infiltration. (AAMA rating of 0.04)
3. A patented sliding system features robust, adjustable dual tandem 1" Ultrex rollers with marine ball bearings to ensure smooth, easy, and quiet operation.
4. An exclusive, high performance water drainage system is incorporated into the lower sill, directing water where it should go... outside.
5. Prima Vista sliding patio doors have fusion welded sashes and are constructed with steel reinforcement at the interlock meeting rails and the lock rail to ensure maximum rigidity for superior construction.
6. Prima Vista's Silent Glide extruded screen with stainless steel screws and an adjustable spring loaded suspension system in each corner is designed not to derail or jam. Self-cleaning tracks are built into the sill for smooth operation of the rigid enameled aluminum alloy screen frame.
7. Prima Vista sliding patio doors offer tempered 7/8" insulated glass and high performance Low E with argon gas fill and Endur warm edge spacer for added efficiency. With the standard glass package, Prima Vista sliding patio doors receive an NFRC U-Value of .29 and SHGC of .37, yielding excellent thermal performance.
8. AAMA 101 tested: 6-foot patio doors out-perform the competition with a very impressive residential DP-60 rating.



7 *Tempered Insulated Glass*



3 *Patented Sliding System*



5 *Steel Reinforced Meeting Rail*



Beyond Elegance

Replace your old patio door with an elegant “hassle-free” Prima Vista sliding patio door, and you will gain unrivaled security, durability, the ultimate in thermal performance, and ease of operation guaranteed for years to come.

Seaway’s Prima Vista sliding patio doors are built to perform in the toughest conditions and are tested against the most stringent industry standards for air and water infiltration, wind-load resistance, ease of operation, forced entry, and more. Prima Vista sliding patio doors come complete with a lifetime limited warranty.

This means you’ll have lower heating and air conditioning costs, easier cleaning and virtually no maintenance, in addition to increased comfort and total performance satisfaction year-round. And, our superior locking system will allow you to sleep secure in the knowledge that your family is protected.



2250 East 33rd Street
Erie, Pennsylvania 16510
www.seawaymfg.com

Your Assurance of Quality

Due to product changes, improvements, and other factors, Seaway reserves the right to change or delete products described herein without prior notice. Color samples may vary slightly from the actual color finishes due to the limitations of the printing process. Please see your sales representative for an actual sample of finishes. Given the wide variety of configurations available, homeowners who require specific performance ratings should specify such with their Seaway dealer.

Seaway Manufacturing Corp. is a proud supplier of the highest quality premium building and remodeling products. We invite every consumer to carefully examine our products, warranties, and reputation, and we make every attempt to choose only the most outstanding, independent remodeling companies to distribute our products. As a manufacturer, we do not control or take responsibility for the actions or conduct of contractors that may sell or install Seaway products.

Your Authorized Seaway Dealer